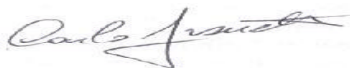

LIQUID CRYSTAL DISPLAY MODULE

L 2 0 1 2 (R e f l e c t i v e t y p e)

Product Specification & Delivery Specification

Approvals

QA	
Design	
Customer approval	

1.	REVISION RECORD	2
2.	REFLECTIVE MODE VERSIONS	2
3.	SCOPE	3
4.	PRODUCT SPECIFICATIONS.....	3
4.1.	GENERAL.....	3
4.2.	MECHANICAL CHARACTERISTICS	3
4.3.	ABSOLUTE MAXIMUM RATINGS	4
4.4.	ELECTRICAL CHARACTERISTICS	4
4.5.	OPTICAL CHARACTERISTICS	5
1.6.	CIRCUIT BLOCK DIAGRAM	8
1.7.	MECHANICAL DIMENSIONS	9
1.8.	PIN CONNECTION (SIGNAL FUNCTION)	10
5.	RELIABILITY.....	11
5.1.	RELIABILITY.....	11
5.2.	LIQUID CRYSTAL PANEL SERVICE LIFE.....	11
5.3.	DEFINITION OF PANEL SERVICE LIFE	11
6.	OPERATIONS PRECAUTIONS.....	12
7.	DELIVERY SPECIFICATIONS: SCOPE	13
8.	MARKINGS	13
9.	SHIPPING METHOD.....	13
9.1.	INDIVIDUAL PACKAGING	13
9.2.	INTERNAL PACKAGING	13
9.3.	EXTERNAL PACKAGING	13
10.	RECEIVING INSPECTION	14
10.1.	GENERAL.....	14
10.2.	NOTE	14
11.	QUALITY ASSURANCE	14
11.1.	CONFORMITY.....	14
11.2.	RESPONSIBILITY	14
11.3.	WARRANTY	14
11.4.	SHIPPING ASSURANCE	15
12.	DEALING WITH CUSTOMER COMPLAINTS.....	20
12.1.	GENERAL.....	20
12.2.	COMPLAINT PROCESSING CHART.....	21
13.	CHANGE OF SPECIFICATIONS	21

1. REVISION RECORD

Date	Revision	Notes
Jan 2002	1	Issued NEW Version

2. REFLECTIVE MODE VERSIONS

Product Name	Description
L201200U000T	20x2 STN RE WR 6H

3. SCOPE

This specification covers the engineering requirements for the liquid crystal display module.

4. PRODUCT SPECIFICATIONS

4.1. General

- 5x8 dot matrix
- 1/16 duty
- Wide operating temperature range

4.2. Mechanical Characteristics

Item	Symbol
Dot configuration	5x8 dot matrix,20 characters x 2 lines
Dot dimensions (mm)	0.60x 0.65
Dot spacing (mm)	0.05
Module dimensions(H x V x T, mm)	116.0 x 37.0x 11.3 MAX
Viewing area (H x V, mm)	83.5 x 18.6
Weight (g)	-

4.3. Absolute Maximum Ratings

Item	Symbol	Condition	Min	Max	Unit
Power supply voltage	VDD		-0.3	6.0	V
	VLC		VDD - 7.0	VDD	V
Input voltage	Vin		-0.3	VDD + 0.3	V
Operating temperature	Topr		-20	70	°C
Storage temperature	Tstg		-30	80	°C

4.4. Electrical Characteristics

VDD=5.0V±5%, VSS = 0 V, Temp = 0 to 50 °C

Item	Symbol	Condition	Min	Typ	Max	Unit
Power supply voltage	VDD		4.75	5.0	5.25	V
	VDD-VLC		3	-	6.3	V
Input voltage	High V _{IH}		2.2	-	VDD	V
	Low V _{IL}		0	-	0.6	V
Output voltage	High V _{OH}	IOH = 0.205 mA	2.4	-	-	V
	Low V _{OL}	IOL = 1.2 mA	-	-	0.4	V
Current consumption*	IDD	Ta = 25°C VLC = 0.25V	-	1.6	2.5	mA
			-	0.4	1.0	mA

* Test pattern: checker board pattern

4.5. Optical Characteristics

4.5.1. Optical characteristics

1 / 16 duty, $V_{opr}=V_{DD}-V_{LC}$

Item	Conditions	Temp.	Symbol	Min	Typ	Max	Unit
Contrast *	$\theta = + 25^\circ$ $\Phi = 0^\circ$ $V_{DD} = 4.75 \text{ V}$	21 °C	C		5		
Viewing angle	$C \geq 2$ $\Phi = 0^\circ$ $V_{op} = 4.75 \text{ V}$	21 °C	$\theta 1$	-	-	-15	deg
			$\theta 2$	55	-	-	
			$\theta 2 - \theta 1$	70	-	-	
Response time	$\theta = 0^\circ$ $\Phi = 0^\circ$ $V_{op} = 4.75 \text{ V}$	21 °C	t_{ON}	-	150	200	ms
			t_{OFF}	-	200	220	
	$\theta = 0^\circ$ $\Phi = 0^\circ$ $V_{op} = 4.75 \text{ V}$	0 °C	t_{ON}	-	750	800	
			t_{OFF}	-	600	700	

Measuring equipment:

Contrast and viewing angle: EZC Eldim

Response time: Canon illuminometer LC-4SR

* Contrast measurement

With pixels ON, direct a halogen lamp at the display, receive the reflected light with a light receiving element and convert the quantity of reflected light to voltage; repeat the measurement with pixels OFF. Calculate the contrast as shown in the following section.

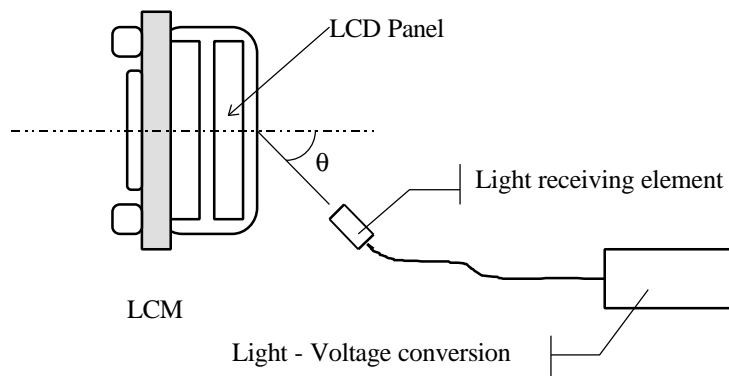

4.5.2. Definition of optical characteristics

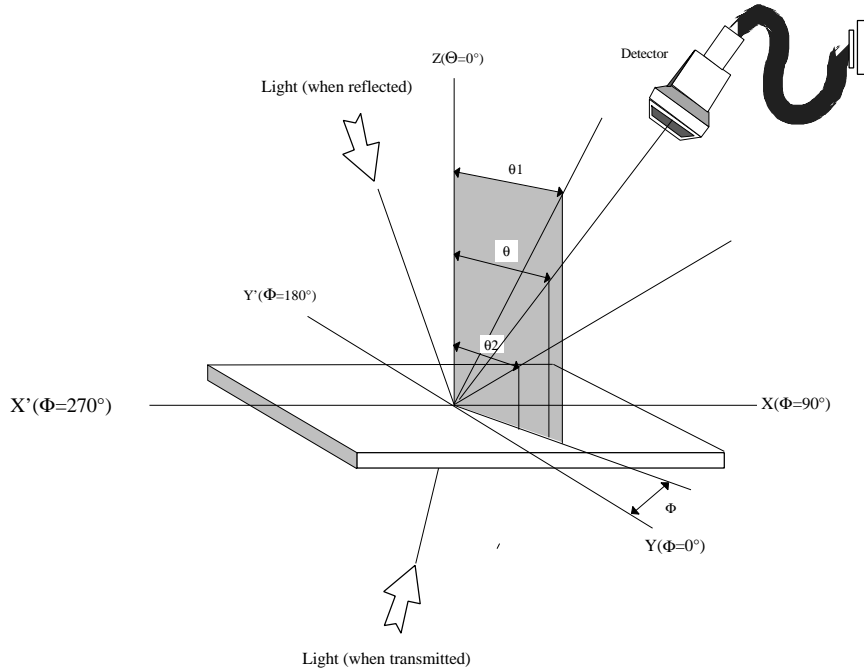

Definition of contrast Cr. $Cr. = \frac{B1}{B2} = \frac{\text{Brightness of not selected segment}}{\text{Brightness of selected segment}}$

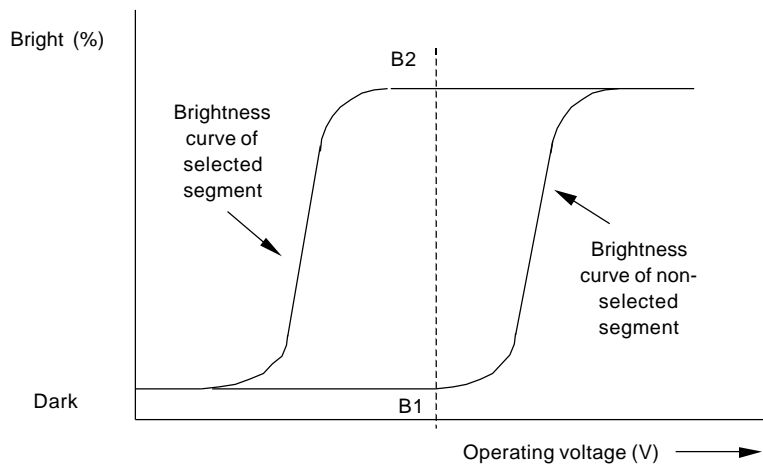

4.5.3. Definition of viewing angle

Definition of viewing angle θ_1 and θ_2

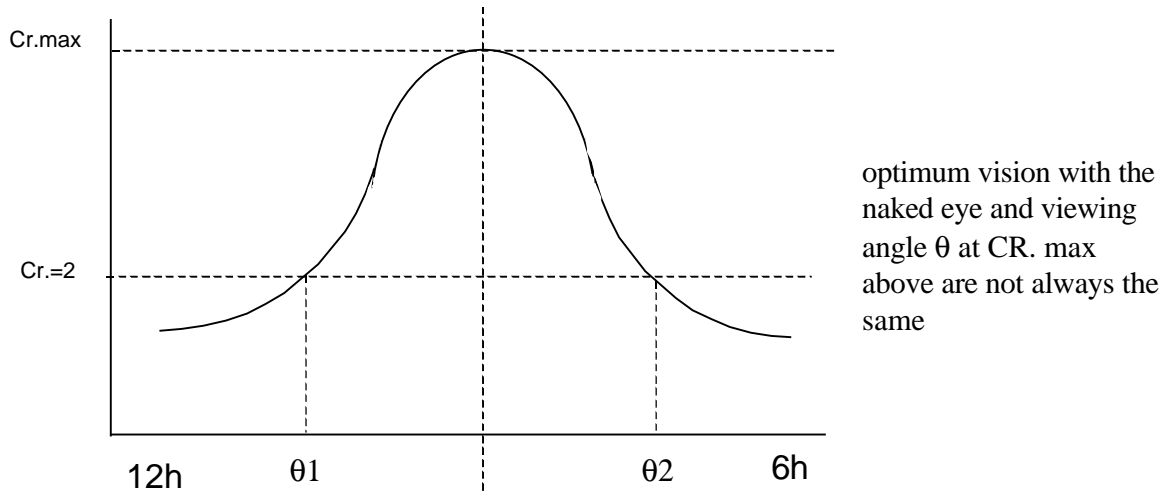

4.5.4. Definition of response time

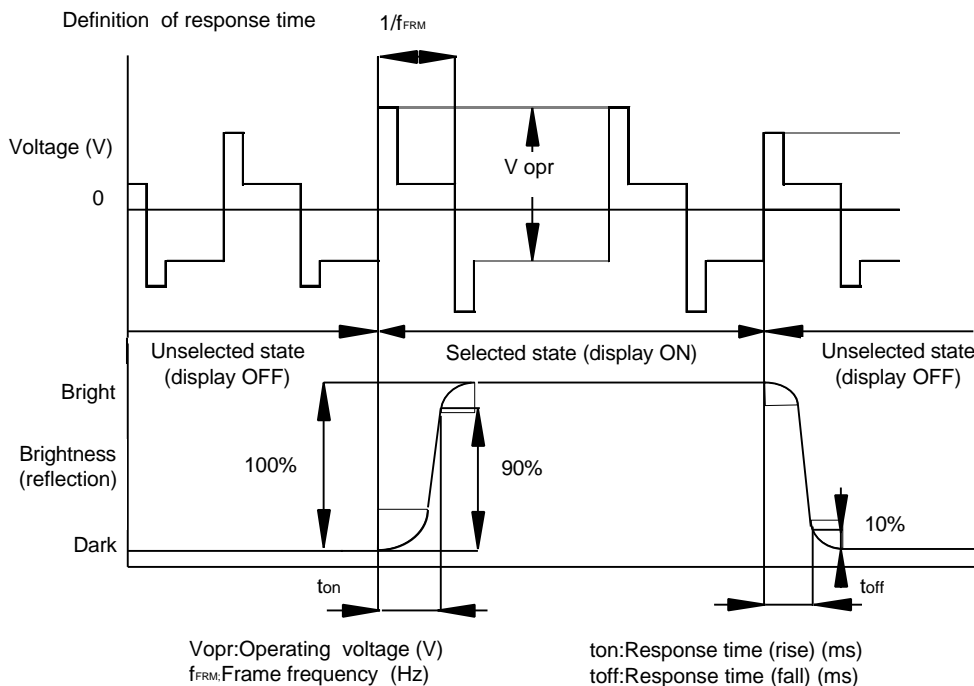

4.6. Circuit Block Diagram

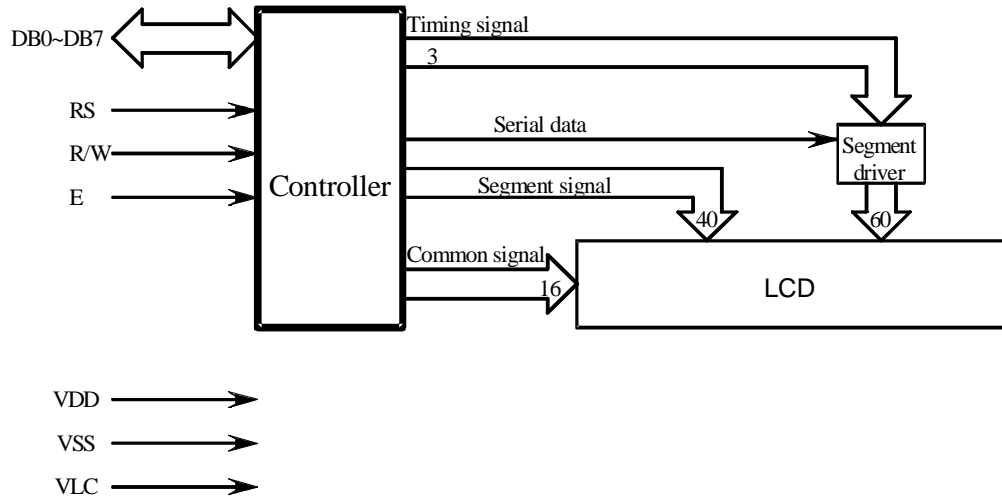

4.8. Pin connection (signal function)

No.	Symbol	Function
1	VSS	GND
2	VDD	Power supply voltage +5 V
3	VLC	Liquid crystal driving voltage
4	RS	H: Data register; L: Instruction register
5	R/W	H: Read; L: Write
6	E	Enable
7	DB0	Data Bus Line
8	DB1	Data Bus Line
9	DB2	Data Bus Line
10	DB3	Data Bus Line
11	DB4	Data Bus Line
12	DB5	Data Bus Line
13	DB6	Data Bus Line
14	DB7	Data Bus Line
15	A	Anode
16	K	Cathode

Pins 15 and 16 are used for LED backlight version only

5. RELIABILITY

5.1. Reliability

Test item	Test Condition	Evaluation and assessment
Operation at high temperature and humidity	60°C ± 2°C 90% RH for 500 hours	No abnormalities in functions* and appearance**
Operation at high temperature	80°C ± 2°C for 500 hours	No abnormalities in functions* and appearance**
Heat shock	-40°C +80°C, Left for 1 hour at each temperature, transition time 5 min, repeated 10 times	No abnormalities in functions* and appearance**
Low temperature	-30 ± 2°C for 500 hours	No abnormalities in functions* and appearance**
Vibration	Sweep for 1 min at 10 Hz, 55 Hz, 10 Hz, amplitude 1.5 mm 2 hrs each in the X, Y, and Z directions	No abnormalities in functions* and appearance**
Drop shock	Dropped onto a board from a height of 30 cm	No abnormalities in functions* and appearance**

* Dissipation current, contrast and display functions

** Polarizing filter deterioration, other appearance defects

5.2. Liquid crystal panel service life

100,000 hours minimum at 25°C ± 10 °C, 65% RH maximum.

5.3. Definition of panel service life

- Contrast becomes 30% of initial value
- Current consumption becomes three times higher than initial value
- Remarkable alignment deterioration occurs in LCD cell layer
- Unusual operation occurs in display functions

6. OPERATIONS PRECAUTIONS

Safety

- If the LCD panel breaks, be careful not to get the liquid crystal in your mouth or in your eyes.
- If the liquid crystal touches your skin or clothes, wash it off immediately using soap and plenty of water.

Handling

- Avoid static electricity as this can damage the CMOS LSI.
- The LCD panel is plate glass; do not hit or crush it.
- Do not remove any part or component from the module.
- The polarizing plate of the display is very fragile; handle it very carefully.

Mounting and Design

- To protect the module from external pressure, place a transparent plate (e.g. acrylic or glass) on the display surface. Leave a small gap between the transparent plate and the display surface.
- Design the system so that no input signal is given unless the power-supply voltage is applied.
- Keep the module dry. Avoid condensation, otherwise the transparent electrodes may break.

Storage

- Store the module in a dark place where the temperature is $25^{\circ}\text{C} \pm 10^{\circ}\text{C}$ and the humidity below 65% RH.
- Do not store the module near organic solvents or corrosive gases.
- Do not crash, shake or jolt the module (including accessories).

Cleaning

- Do not wipe the polarizing plate with a dry cloth, as it may scratch the surface.
- Wipe the module gently with a soft cloth soaked with a perfluorine-hexane or iso-propanol.
- Do not use ketonic solvents (ketone and acetone) or aromatic solvents (toluene and xylene), as they may damage the polarizing plate.

7. DELIVERY SPECIFICATIONS: SCOPE

This Specification covers the delivery requirements for the liquid crystal display module delivered by Tecdis S.p.A. See Product Specifications for specifications and reliability.

8. MARKINGS

Marking	Method	Component
L2012***	Etching	Circuit board

9. SHIPPING METHOD

9.1. Individual Packaging

The products are packaged in antistatic bags (to prevent static electricity).

9.2. Internal Packaging

Cartons are used for internal packaging : INNER BOXES .Labels clearly specifying the contents are affixed to the internal packaging.

9.2.1. Inner Box Label

Following informations are described:

- Tecdis address
- Tecdis code
- Customer code
- Lot number
- Production date
- Number of LCMs

9.3. External Packaging

Cartons are used external packaging : MASTER CARTONS .Labels clearly specifying the contents are affixed to the external packaging.

9.3.1. Master Carton Label

Following informations are described:

- Tecdis address
- Tecdis code
- Customer code
- Data of print
- Number of LCMs
- Gross W. Kg
- Net W. Kg

10. RECEIVING INSPECTION

10.1. General

Check the quality and the quantity of the product that ordered within one month after having received it. This completes the acceptance inspection. You shall inform Tecdis S.p.A. of the results.

10.2. Note

We will follow Item 11 to deal with any products that don't conform to the Product Specifications.

11. QUALITY ASSURANCE

11.1. Conformity

The performance, functions and reliability of the shipped products conform to the Product Specifications.

11.2. Responsibility

You are responsible for any defect in quality caused after receiving inspection.

11.3. Warranty

The quality warranty is valid for one year after delivery.

11.4. Shipping Assurance.

11.4.1. Shipping inspection standards.

Shipping inspection standard is MIL-STD 105 D single sampling level, level II.
The quality assurance levels are shown below:

Rank	Zone	Defect	A.Q.L.
Major defect	A	Display area (Appearance) (Functions)	0.4%
Minor defect	A	Display area	1.0%

11.4.2. Zone definitions

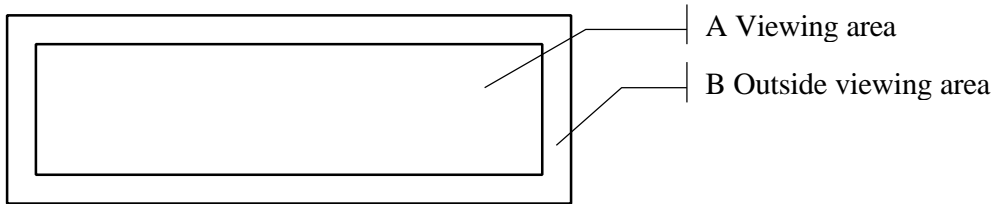

A: Viewing area.

B: Outside viewing area.

11.4.3. Visual inspection

- Inspect under 15W fluorescent lamp (approximately 2500 lux) leaving 25 cm to 30 cm between the modules and lights and 30 cm between the module and the eye (measuring position).
- Apperance is inspected at the best contrast voltage (best contrast is adjusted to consider clearness and crosstalk on screen).
- Inspect the module at 45° right and left, front and rear.
- Use the maximum angle for the viewing angle direction contrast during the contrast inspection.

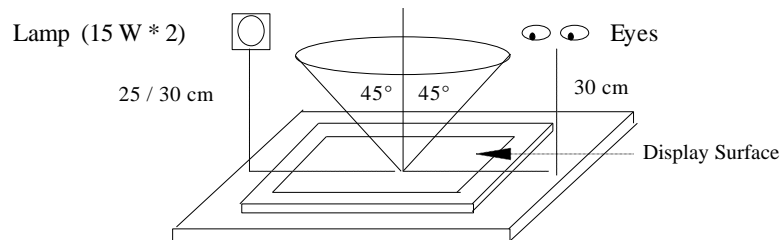

11.4.4. Visual standards

When the panel doesn't display

11.4.4.1. Tolerance number of defect

When the number of defects in items 1 to 5 of "Individual appearance standard defects" is totalled, the maximum number of defects is 5 in zone A.

11.4.4.2. Individual appearance defects standards (display OFF)

No	Item	Detail	Section (mm)	Zone A	Zone B
1	Black/white spots	Black/White spots caused by dust, bubbles or defective alignment in the cell or polarizer (plus black spots of the backlight)	$\Phi \leq 0.10$	Any number	Any number
			$0.10 < \Phi \leq 0.20$	1	
			$0.20 < \Phi$	0	
2	Black/white streaks	Black/White streaks caused by alignment scratches or dust in the orientation of the cell or polarizer	$W \leq 0.01$	Any number	Any number
			$W \leq 0.02$ $L \leq 0.20$	3	
			$W \leq 0.03$ $L \leq 0.20$	2	
			$W \leq 0.05$ $L \leq 0.20$	1	
			$W \leq 0.06$ $L \leq 0.20$	1	
Other than above			0		
3	Bubble between glass and polarizer	Bubble between the glass and the polarizer	$\Phi \leq 0.20$	Any number	Any number
			$0.20 < \Phi \leq 0.50$	3	
			$0.50 < \Phi \leq 1.0$	1	
			$1.0 < \Phi$	0	
			$W \leq 0.15$ $L \leq 5.0$	2	
			$W \leq 0.15$ $L \leq 10.0$	1	
Other than above			0		
4	Scratches on the polarizer	Scratches on the polarizer	Visible with the naked eye	Same as No2	Any number
			Not visible with the naked eye	Any number	
5	Dent on polarizer	Dent on the polarizer	$\Phi \leq 0.50$	2	Any number
			$0.50 < \Phi \leq 1.0$	1	
			$1.0 < \Phi$	0	
6	Chromaticity and uniformity	Streaks and uneven color		Level of sample for approval set as limit sample	

No	Item	Detail	Section (mm)	Zone A	Zone B
7	Dirt	Dirt on the polarizer, panel frame, PCB		Products pass if the dirt can be wiped off easily	

11.4.4.3. Individual appearance defects standards (display ON)

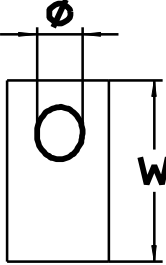
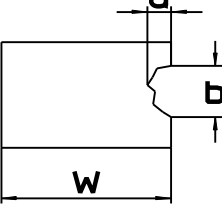
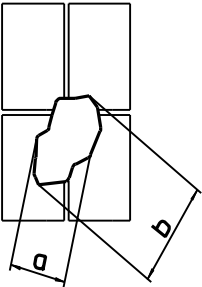
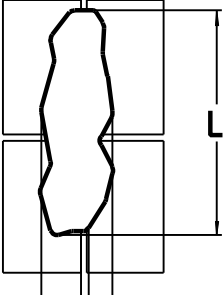
No	Item	Detail	Section (mm)	Standard Max No of defects
1	No display	Part or all of the screen doesn't light because of an open or a short circuit		Must not occur
2	Display missing	Part of display segment missing because of pin holes or an open 		W=0.32
			$\Phi \leq 0.10$	Any number
			$0.10 < \Phi \leq 0.20$	3
			$0.20 < \Phi \leq 0.25$	2
			$0.25 < \Phi \leq 0.30$	1
3	Display missing	Part of display segment missing because of pin holes or an open 		W=0.32
			$a \leq 0.10$ $b \leq 0.10$	Any number
			$a \leq 0.20$ $b \leq 0.25$	3
			$a \leq 0.25$ $b \leq 0.30$	2
			$a > 0.25$ $b > 0.30$	0
4	Display missing a,b	Thin part of display segment / common missing 	$a \leq 0.03$	Any number
			$a \leq 0.05$ $b < 0.50$	3
			$a \leq 0.10$ $b \leq 0.30$	2
			$a \leq 0.20$ $b \leq 0.30$	1
			$a \leq 0.25$ $b \leq 0.30$	0
5	Display missing a,L	Thin part of display segment / common missing 	$a \leq 1.2S$	Any number

No	Item	Detail	Section (mm)	Standard Max No of defects
			$a \leq 1.4S$ $L \leq 10.0$	2
			$a \leq 1.4S$ $b > 10.0$	0
			$a > 1.4S$	0

12. DEALING WITH CUSTOMER COMPLAINTS

12.1. General

- If any defective products are found during the acceptance inspection that Tecdis S.p.A. is clearly responsible for, treat them as lot out or defective products and return them to Tecdis S.p.A. Any product that are not clearly defective or that Tecdis S.p.A. is not clearly responsible for will be dealt with by discussion between both companies.
- When defective products are caused after acceptance inspection, inform Tecdis S.p.A. The product will be dealt with by discussion between both companies.
- When returning defective products to Tecdis S.p.A., pack them individually in their original packing to prevent static electricity, and pad them with cushions to prevent vibration. Do not place them on top of one other.

12.2. Complaint processing Chart

Inspection and notification of any defect is shown in the diagram below:

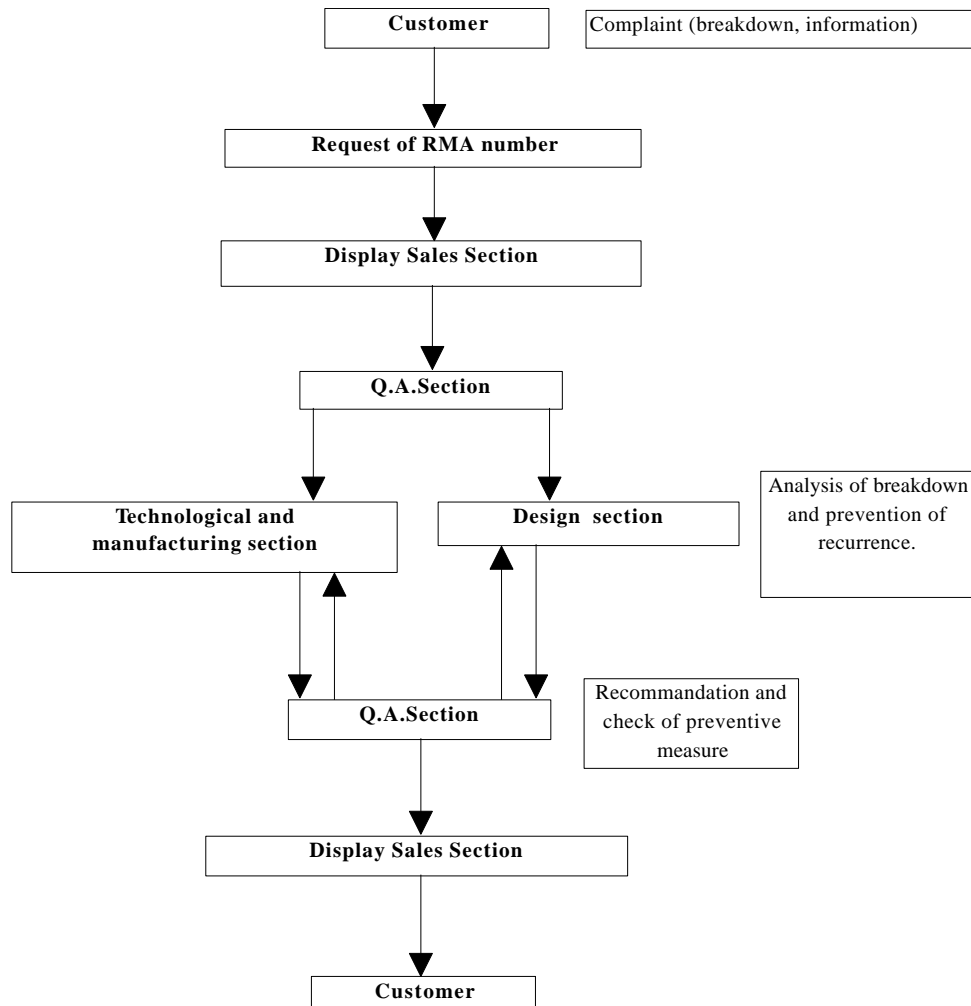

13. CHANGE OF SPECIFICATIONS

Any changes that need to be made in this specification or any problems arising from it will be dealt with by discussion between both companies.