



| | | |
|---|------|----------|
| LCD MOUDULE SPECIFICATION FOR APPROVAL | DATE | 10/12/03 |
| | VER. | 1.0 |
| JHD12864E | PAGE | 1 |

CUSTOMER:

P/N : JHD12864E

CUSTOMER APPROVAL

| | | |
|---------|---------|----------|
| CHECKED | CHECKED | APPROVAL |
| | | |

SUPPLIER APPROVAL

| | | |
|---------|---------|----------|
| CHECKED | CHECKED | APPROVAL |
| | | |

Tel: 86-755-83779545

Fax: 86-755-83779544

Address: Room A512, Baohua office building,
Shenzhen, P. R. China

E-mail: jhd2@baohua.com.cn

Website: www.jhdlcd.com.cn

| | | |
|---|------|----------|
| LCD MOUDULE SPECIFICATION FOR APPROVAL | DATE | 10/12/03 |
| | VER. | 1.0 |
| JHD12864E | PAGE | 3 |

CONTENTS

| | | |
|-----|---------------------------------------|-------|
| 1. | FEATURES | 4 |
| 2. | MECHANICAL SPEC | 4 |
| 3. | ABSOLUTE MAXIMUM RATING | 5 |
| 4. | ELECTRICAL CHARACTERISTICS | 5 |
| 5. | ELECTRO-OPTICAL CHARACTERISTICS | 6 |
| 6. | QC/QA PROCEDURE | 7 |
| 7. | RELIABILITY | 8 |
| 8. | BLOCK DIAGRAM | 9 |
| 9. | POWER SUPPLY | 9 |
| 10. | TIMIING DIAGRAM | 10 |
| 11. | AC CHARACTERISTICS..... | 11 |
| 12. | INSTRUCTION SET | 12 |
| 13. | HANDLING PRECAUTION..... | 13-15 |
| 14. | EXTERNAL DIMENSION | 16 |
| 15. | INTERFACE | 17 |

| | | |
|---|------|----------|
| LCD MOUDULE SPECIFICATION FOR APPROVAL | DATE | 10/12/03 |
| | VER. | 1.0 |
| JHD12864E | PAGE | 4 |

1. FEATURES

- Display construction..... 128*64 DOTS
- Display mode STN / Yellow Green
- Display type Positive Tranflective
- Backlight..... LED(Y/G)/5.0V
- Viewing direction..... 6 o' clock
- Operating temperature..... Indoor
- Driving voltage..... Single power
- Driving method..... 1/64 duty, 1/9 bias
- Type..... COB (Chip On Board)
- Number of data line..... 8-bit parallel
- Connector..... Pin

2. MECHANICAL DATA

| ITEM | | WIDTH | HEIGHT | THICKNESS | UNIT |
|---------------------------|-------|----------|--------|------------|------|
| Module size | | 93.0 | 70.0 | 14.0 (MAX) | mm |
| Viewing area | | 70.7 | 38.8 | - | mm |
| Dot | Size | 0.48 | 0.48 | - | mm |
| | Pitch | 0.52 | 0.52 | - | mm |
| Diameter of mounting hole | | 2.7 | | | mm |
| Weight | | About 50 | | | g |

| | | |
|--|------|----------|
| LCD MODULE SPECIFICATION FOR APPROVAL | DATE | 10/12/03 |
| | VER. | 1.0 |
| JHD12864E | PAGE | 5 |

3. ABSOLUTE MAXIMUM RATINGS

| Characteristic | Symbol | Value | Unit | Note |
|-----------------------|-----------|-------------------------------|------|----------|
| Operating voltage | V_{DD} | -0.3 to +7.0 | V | (1) |
| Supply voltage | V_{EE} | $V_{DD}-19.0$ to $V_{DD}+0.3$ | V | (4) |
| Driver supply voltage | V_B | -0.3 to $V_{DD}+0.3$ | V | (1), (3) |
| | V_{LCD} | $V_{EE}-0.3$ to $V_{DD}+0.3$ | V | (2) |
| Operating temperature | T_{OPR} | -30 to +85 | °C | |
| Storage temperature | T_{STG} | -55 to +125 | °C | |

4. ELECTRICAL CHARACTERISTICS

($V_{DD} = +5V \pm 10\%$, $V_{SS} = 0V$, $V_{DD}-V_{EE} = 8$ to $17V$, $T_a = -30$ to $+85^\circ C$)

| Characteristic | Symbol | Condition | Min | Typ | Max | Unit | Note |
|--------------------------------|-----------|---|-------------|-----|-------------|------------|------|
| Input high voltage | V_{IH1} | – | $0.7V_{DD}$ | – | V_{DD} | V | (1) |
| | V_{IH2} | – | 2.0 | – | V_{DD} | V | (2) |
| Input low voltage | V_{IL1} | – | 0 | – | $0.3V_{DD}$ | V | (1) |
| | V_{IL2} | – | 0 | – | 0.8 | V | (2) |
| Output high voltage | V_{OH} | $I_{OH} = -200\mu A$ | 2.4 | – | – | V | (3) |
| Output low voltage | V_{OL} | $I_{OL} = 1.6mA$ | – | – | 0.4 | V | (3) |
| Input leakage current | I_{LKG} | $V_{IN} = V_{SS} - V_{DD}$ | -1.0 | – | 1.0 | μA | (4) |
| Three-state(off) input current | I_{TSL} | $V_{IN} = V_{SS} - V_{DD}$ | -5.0 | – | 5.0 | μA | (5) |
| Driver input leakage current | I_{DIL} | $V_{IN} = V_{EE} - V_{DD}$ | -2.0 | – | 2.0 | μA | (6) |
| Operating current | I_{DD1} | During display | – | – | 100 | μA | (7) |
| | I_{DD2} | During access Access cycle = 1MHz | – | – | 500 | μA | (7) |
| On resistance | R_{ON} | $V_{DD}-V_{EE} = 15V$ $I_{LOAD} = \pm 0.1mA$ | – | – | 7.5 | K Ω | (8) |

| | | |
|--|------|----------|
| LCD MODULE SPECIFICATION FOR APPROVAL | DATE | 10/12/03 |
| | VER. | 1.0 |
| JHD12864E | PAGE | 6 |

5. ELECTRO-OPTICAL CHARACTERISTICS

| ITEM | SYMBOL | CONDITION | MIN. | TYP. | MAX. | UNIT | NOTE |
|----------------------|----------|--------------|------------|------|------|------|------|
| Contrast ratio | K | $\phi = 0$ | 1.4 | 4 | - | - | 1 |
| Response time (rise) | Tr | $\phi = 1$ | - | 130 | - | ms | 2 |
| Response time (fall) | Tf | $\phi = 2$ | - | 130 | - | ms | 2 |
| Viewing angle | ϕ | $K \geq 1.4$ | -40 -- +40 | | | deg. | 3 |
| | θ | | -30 -- +30 | | | | |

Note 1: Definition of Contrast Ratio "K"

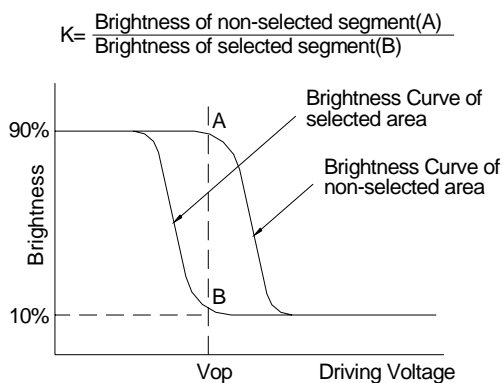

Note 2: Definition of Optical Response Time

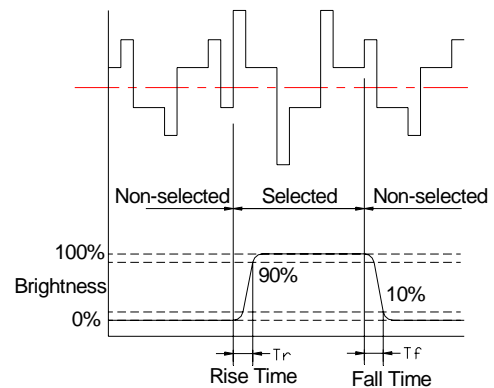

Note 3: Definition of Viewing Angle

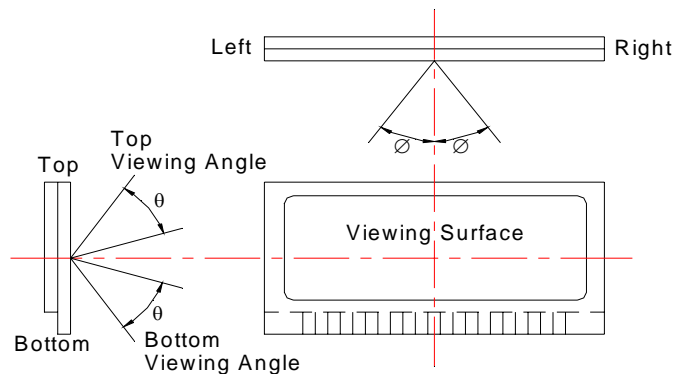

Please select either top or bottom viewing angle

| | | |
|---|------|----------|
| LCD MOUDULE SPECIFICATION FOR APPROVAL | DATE | 10/12/03 |
| | VER. | 1.0 |
| JHD12864E | PAGE | 7 |

6. QC/QA PROCEDURE

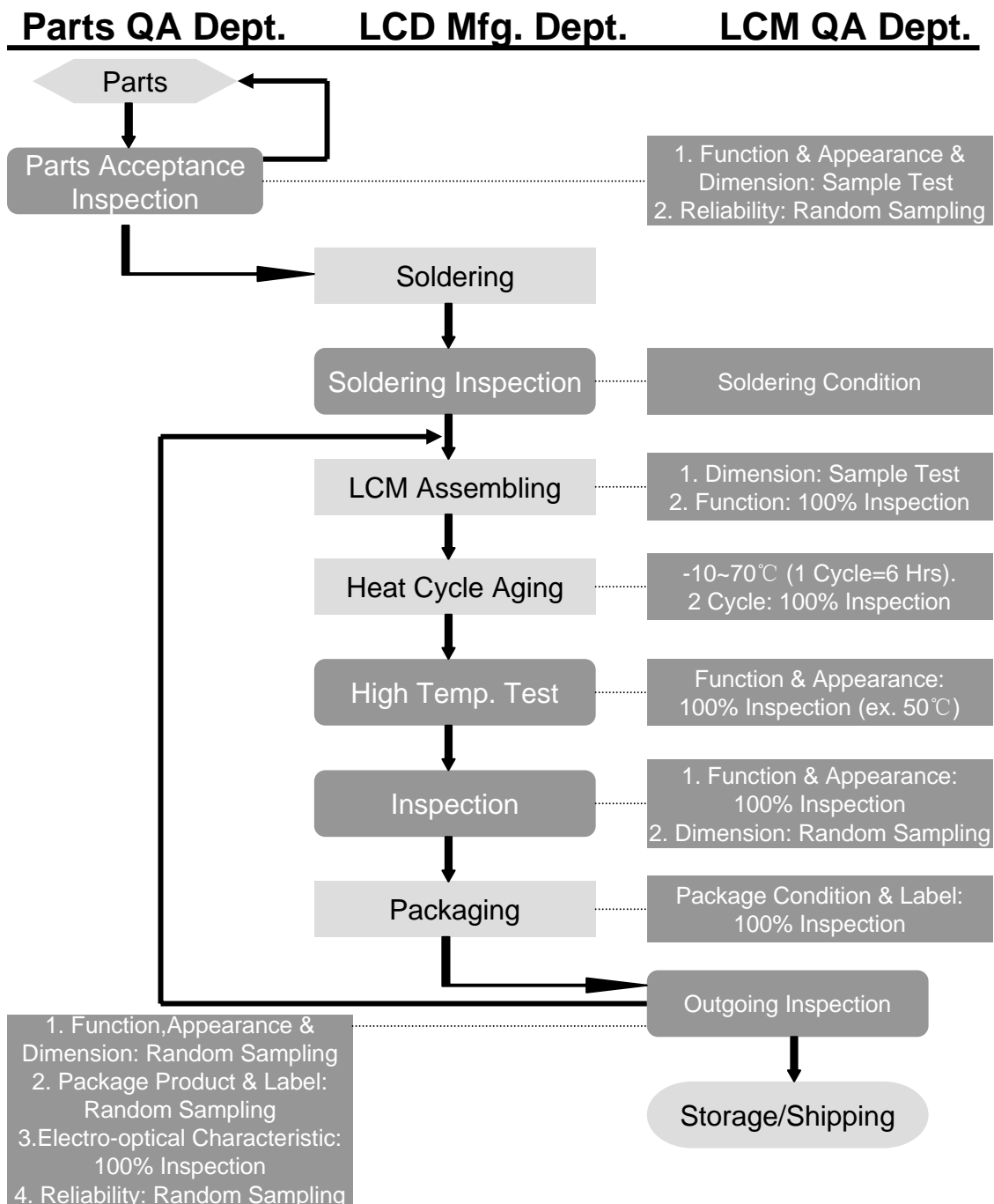

| | | |
|---|------|----------|
| LCD MOUDULE SPECIFICATION FOR APPROVAL | DATE | 10/12/03 |
| | VER. | 1.0 |
| JHD12864E | PAGE | 8 |

7. RELIABILITY

•Operating life time:

Longer than 50000 hours (at room temperature without direct irradiation of sunlight)

•Reliability Characteristics:

| Item | Test | Criterion |
|---------------|--|--|
| High temp | 70°C / 200 Hrs | ■Total current consumption should be below double of initial value ■Contrast ratio should be within initial value±50% ■No defect in cosmetic and operational function is allowable |
| Low temp. | -20°C / 200 Hrs | |
| High humidity | 40°C * 90%RH / 200 Hrs | |
| Thermal shock | -20°C→25°C→70°C→25°C /5 Cycles (30min) (5min) (30min) (5min) | |
| Vibration | 1. Operating time: Thirty minutes exposure in each direction (x, y, z) 2. Sweep Frequency (1min):10Hz→ 55Hz→10Hz 3. Amplitude: 0.75mm double amplitude | |

| | | |
|---|------|----------|
| LCD MOUDULE SPECIFICATION FOR APPROVAL | DATE | 10/12/03 |
| | VER. | 1.0 |
| JHD12864E | PAGE | 9 |

8. BLOCK DIAGRAM

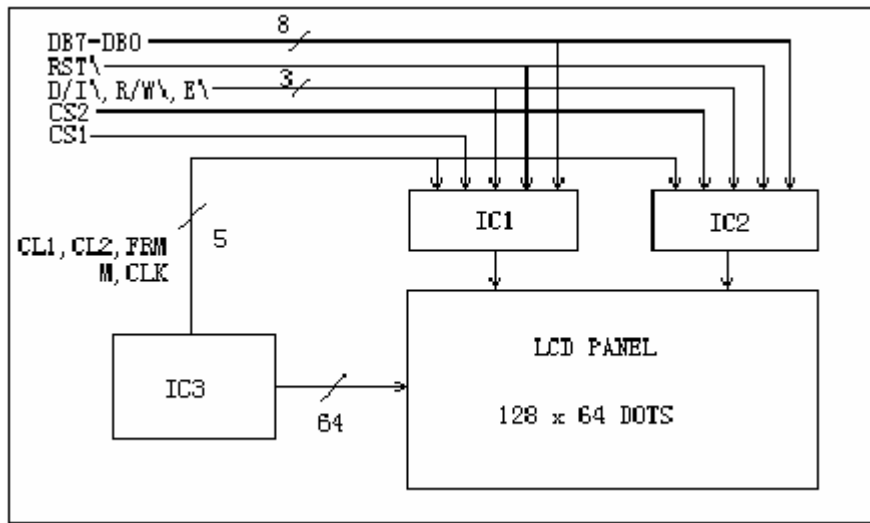

9. POWER SUPPLY

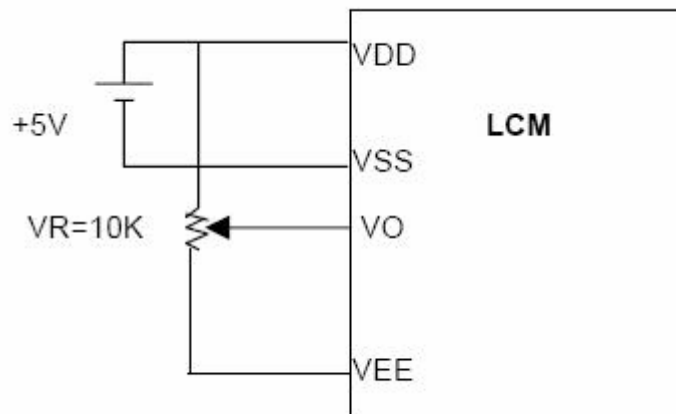

| | | |
|--|------|----------|
| LCD MODULE SPECIFICATION FOR APPROVAL | DATE | 10/12/03 |
| | VER. | 1.0 |
| JHD12864E | PAGE | 10 |

10. TIMING DIAGRAM

- WRITE OPERATION

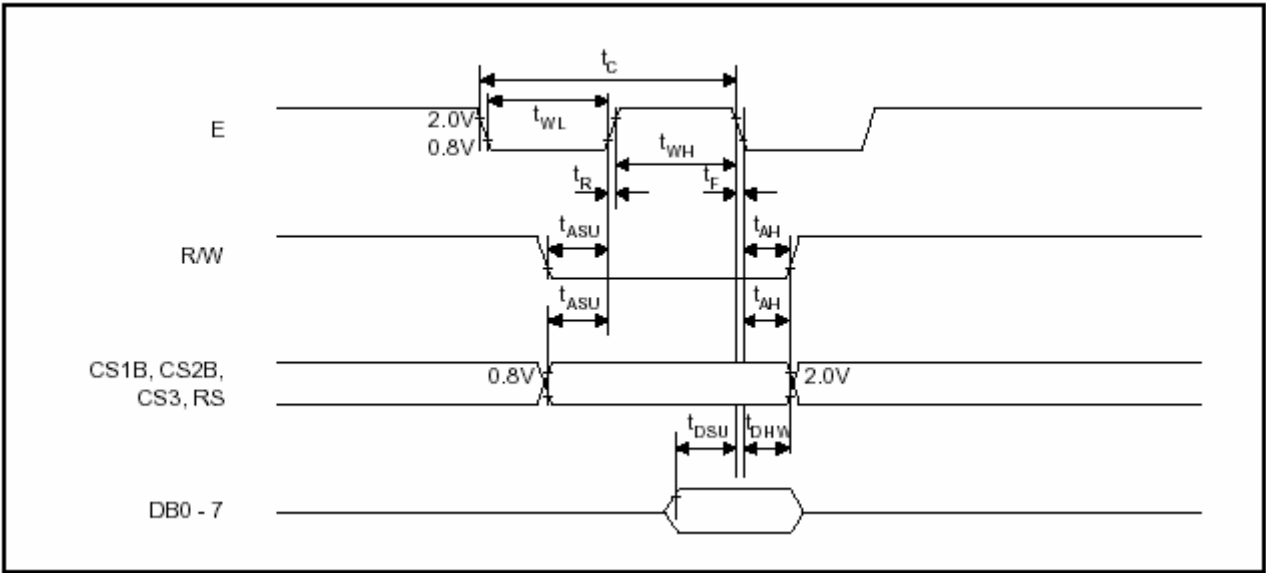

- READ OPERATION

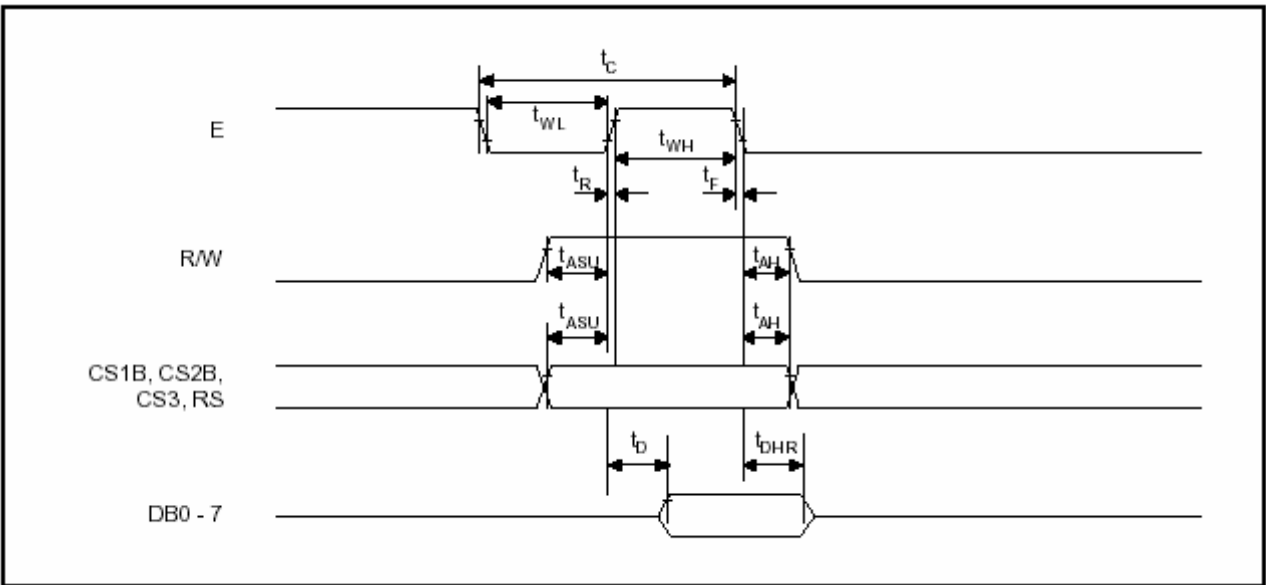

| | | |
|---|------|----------|
| LCD MOUDULE SPECIFICATION FOR APPROVAL | DATE | 10/12/03 |
| | VER. | 1.0 |
| JHD12864E | PAGE | 11 |

11. AC CHARACTERISTICS

MPU Interface

| Characteristic | Symbol | Min | Typ | Max | Unit |
|------------------------|-----------|------|-----|-----|------|
| E cycle | t_C | 1000 | – | – | ns |
| E high level width | t_{WH} | 450 | – | – | ns |
| E low level width | t_{WL} | 450 | – | – | ns |
| E rise time | t_R | – | – | 25 | ns |
| E fall time | t_F | – | – | 25 | ns |
| Address set-up time | t_{ASU} | 140 | – | – | ns |
| Address hold time | t_{AH} | 10 | – | – | ns |
| Data set-up time | t_{DSU} | 200 | – | – | ns |
| Data delay time | t_D | – | – | 320 | ns |
| Data hold time (write) | t_{DHW} | 10 | – | – | ns |
| Data hold time (read) | t_{DHR} | 20 | – | – | ns |

| | | |
|--|------|----------|
| LCD MODULE SPECIFICATION FOR APPROVAL | DATE | 10/12/03 |
| | VER. | 1.0 |
| JHD12864E | PAGE | 12 |

12. INSTRUCTION SET

DISPLAY CONTROL INSTRUCTION

The display control instructions control the internal state of the S6B0108. Instruction is received from MPU to S6B0108 for the display control. The following table shows various instructions.

| Instruction | RS | R/W | DB7 | DB6 | DB5 | DB4 | DB3 | DB2 | DB1 | DB0 | Function | |
|--------------------------------|----|-----|------------|-----|-----------------------------|-------|-----|--------------|-----|-----|---|--|
| Display on/off | L | L | L | L | H | H | H | H | H | L/H | Controls the display on or off. Internal status and display RAM data is not affected. L: OFF, H: ON | |
| Set address (Y address) | L | L | L | H | Y address (0 - 63) | | | | | | Sets the Y address in the Y address counter. | |
| Set page (X address) | L | L | H | L | H | H | H | Page (0 - 7) | | | Sets the X address at the X address register. | |
| Display start line (Z address) | L | L | H | H | Display start line (0 - 63) | | | | | | Indicates the display data RAM displayed at the top of the screen. | |
| Status read | L | H | Busy | L | On/Off | Reset | L | L | L | L | Read status. BUSY L: Ready H: In operation ON/OFF L: Display ON H: Display OFF RESET L: Normal H: Reset | |
| Write display data | H | L | Write data | | | | | | | | | Writes data (DB0:7) into display data RAM. After writing instruction, Y address is increased by 1 automatically. |
| Read display data | H | H | Read data | | | | | | | | | Reads data (DB0:7) from display data RAM to the data bus. |

| | | |
|---|------|----------|
| LCD MOUDULE SPECIFICATION FOR APPROVAL | DATE | 10/12/03 |
| | VER. | 1.0 |
| JHD12864E | PAGE | 13 |

13. Handling Precautions

1. Limitation of Application:

Optrex products are designed for use in ordinary electronic devices such as business machines, telecommunications equipment, measurement devices and etc. Please handle the products with care. (see below)

Optrex products are not designed, intended, or authorized for use in any application which the failure of the product could result in a situation where personal injury or death may occur. these applications include, but are not limited to. life-sustaining equipment, nuclear control devices, aerospace equipment, devices related to hazardous or flammable materials, etc. [If Buyer intends to purchase or use the Optrex Products for such unintended or unauthorized applications, Buyer must secure prior written consent to such use by a responsible officer of Optrex Corporation.] Should Buyer purchase or use Optrex Products for any such unintended or unauthorized application [without such consent]. Buyer shall indemnify and hold Optrex and its officers, employees, subsidiaries, affiliates and distributors harmless against all claims, costs, damages and expenses, and reasonable attorney's fees, arising out of, directly or indirectly, any claim of personal injury or death associated with such unintended or unauthorized use, even if such claim alleges that Optrex was negligent regarding the design or manufacture of the part.

2. Industrial Rights and Patents

Optrex shall not be responsible for any infringement of industrial property rights of third parties in any country arising out of the application or use of Optrex products, except which directly concern the structure or production of such products.

No Press and Shock!

If pressure to LCD, orientation may be disturbed.
LCD will broken by shock!

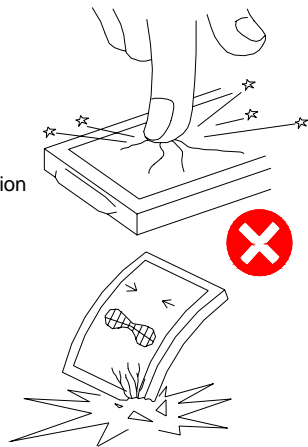

Don't Swallow or Touch Liquid Crystal!

Liquid Crystal may be leaked when display is broked.
If it accidentally gets your hands, wash then with water!

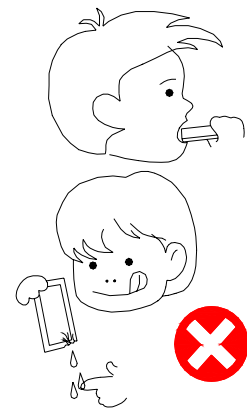

Don't not Scratch!

Polarizer is a soft material and can easily be scratched.

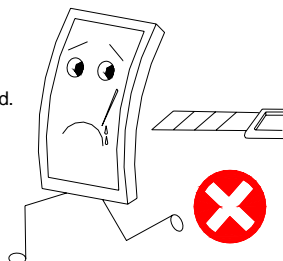

No DC Voltage to LCD!

DC volrage or drivinge higher than the specified voltage will reduce the lifetime of the LCD.

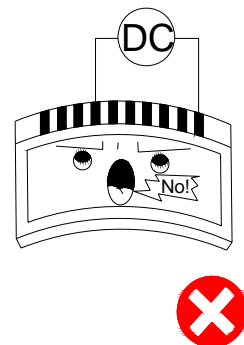

| | | |
|--|------|----------|
| LCD MODULE SPECIFICATION FOR APPROVAL | DATE | 10/12/03 |
| | VER. | 1.0 |
| JHD12864E | PAGE | 14 |

Don't Press the Metallic Frame and Disassemble the LCM

Pressure on the metallic frame and PCB may deform the conductive rubber or break the liquid crystal cell and back light, which will cause defects.

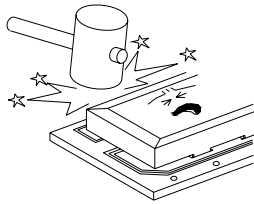

LCD may be shifted or conductive rubber may be reshaped, which will cause defects.

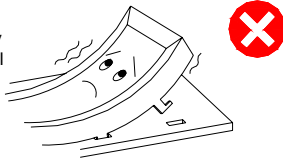

Slowly Peel Off Protective Film!

Avoid static electricity.

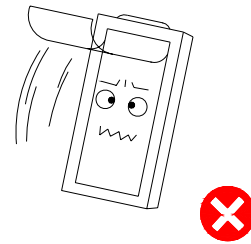

Avoid Static Electricity!

Please be sure to ground human body and electric appliances during work. It is preferable to use conductive mat on table and wear cotton clothes or conduction processed fiber. Synthetic fiber is not recommended.

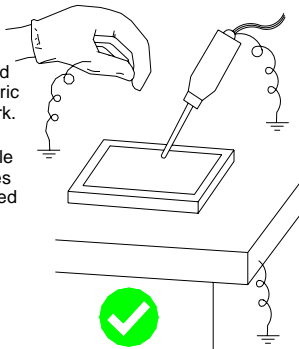

Wear Gloves While Handling!

It is preferable to wear gloves to avoid damaging the LCD.

Please do not touch electrodes with bare hands or make them dirty.

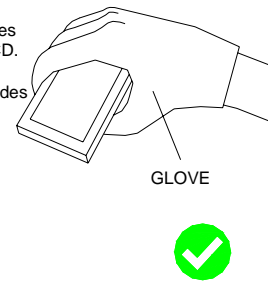

Keep Away From Extreme Heat and Humidity!

LCD deteriorates.

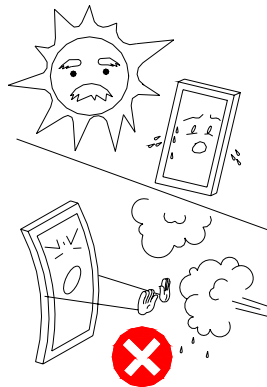

Use Alcohol to Clean Terminals!

When attaching with the heat seal or anisotropically conductive film, wipe off with alcohol before use.

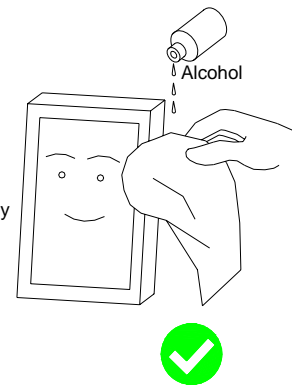

| | | |
|--|------|----------|
| LCD MODULE SPECIFICATION FOR APPROVAL | DATE | 10/12/03 |
| | VER. | 1.0 |
| JHD12864E | PAGE | 15 |

Don't Drop Water on LCD!

Note that the presence of waterdrops or dew in the LCD panel may deteriorate the polarizer or corrode electrode.

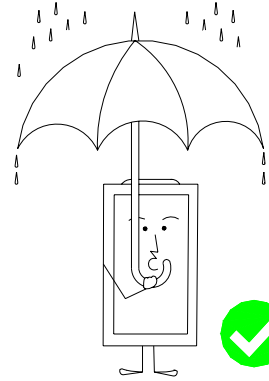

Precaution in Soldering LCD Module

Basic instructions: Solder I/O terminals only.

Use soldering iron without leakage.

(1) Soldering condition to I/O terminals

Temperature at tip of the iron: $280 \pm 10^{\circ}\text{C}$

Soldering time: 3~4 sec.

Type of solder: Eutectic solder (containing colophony-flux)

*Please do not use flux because it may soak into LCD Module or contaminate it.

*It is preferable to peel off protective film on display surface after soldering I/O terminals is finished.

(2) Remove connector or cable

*When you remove connector or cable soldered to I/O terminals, please confirm that solder is fully melted. If you remove by force, electrodes at I/O terminals may be damaged (or stripped off).

*It is recommended to use solder suction machine.

Long-term Storage

If it is necessary to store LCD modules for a long time, please comply with the following procedures.

If storage condition is not satisfactory, display (especially polarizer) may be deteriorated or soldering I/O terminals may become difficult (some oxide is generated at I/O terminals plating).

1. Store as delivered by Optrex

2. If you store as unpacked, put in anti-static bag, seal its opening and store where it is not subjected to direct sunshine nor fluorescent lamp.

3. Store at temperature 0 to $+35^{\circ}\text{C}$ and at low humidity. Please refer to our specification sheets for storage temperature range and humidity condition.

Long-term Storage

Please use power supply with built-in surge protection circuit.

| | | |
|---|------|----------|
| LCD MOUDULE SPECIFICATION FOR APPROVAL | DATE | 10/12/03 |
| | VER. | 1.0 |
| JHD12864E | PAGE | 16 |

14. EXTERNAL DIMENSION

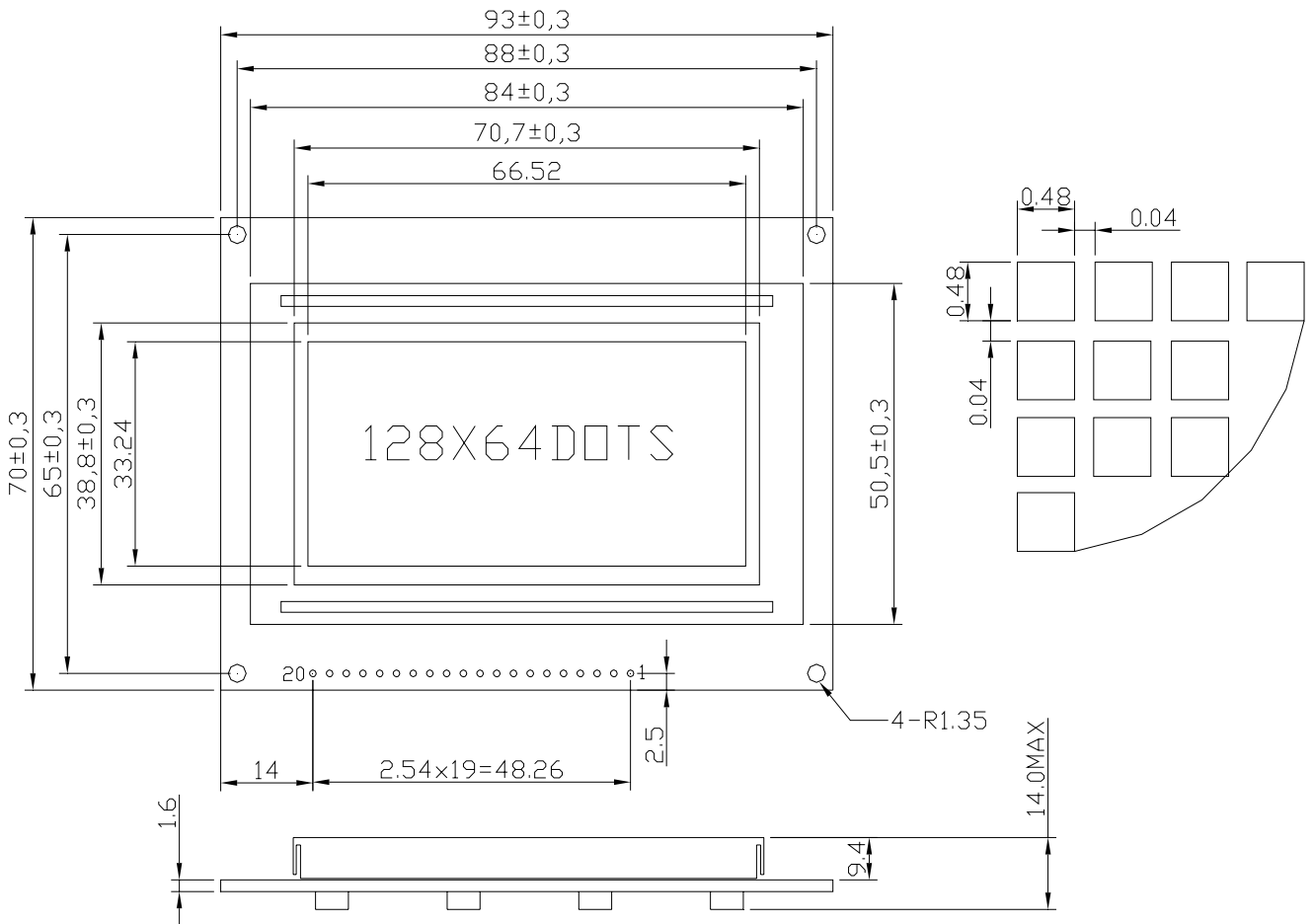

| | | | | | | | | | |
|-----|-----|-----|-----|-----|-----|-----|-----|------|------|
| 1 | 2 | 3 | 4 | 5 | 6 | 7 | 8 | 9 | 10 |
| VSS | VDD | V0 | D/I | R/W | E | DB0 | DB1 | DB2 | DB3 |
| 11 | 12 | 13 | 14 | 15 | 16 | 17 | 18 | 19 | 20 |
| DB4 | DB5 | DB6 | DB7 | CS1 | CS2 | RST | VEE | LED+ | LED- |

| | | |
|---|------|----------|
| LCD MOUDULE SPECIFICATION FOR APPROVAL | DATE | 10/12/03 |
| | VER. | 1.0 |
| JHD12864E | PAGE | 17 |

15. INTERFACE

| PIN NO. | SYMBOL | DESCRIPTION | FUNCTION |
|---------|--------|-------------------------------------|---|
| 1 | VSS | GROUND | 0V (GND) |
| 2 | VDD | POWER SUPPLY FOR LOGIC CIRCUIT | +5V |
| 3 | V0 | LCD CONTRAST ADJUSTMENT | |
| 4 | RS | INSTRUCTION/DATA REGISTER SELECTION | RS = 0 : INSTRUCTION REGISTER RS = 1 : DATA REGISTER |
| 5 | R/W | READ/WRITE SELECTION | R/W = 0 : REGISTER WRITE R/W = 1 : REGISTER READ |
| 6 | E | ENABLE SIGNAL | |
| 7 | DB0 | DATA INPUT/OUTPUT LINES | 8 BIT: DB0-DB7 |
| 8 | DB1 | | |
| 9 | DB2 | | |
| 10 | DB3 | | |
| 11 | DB4 | | |
| 12 | DB5 | | |
| 13 | DB6 | | |
| 14 | DB7 | | |
| 15 | CS1 | CHIP SELECTION | CS1=1,CHIP SELECT SIGNAL FOR IC1 |
| 16 | CS2 | CHIP SELECTION | CS2=1,CHIP SELECT SIGNAL FOR IC2 |
| 17 | RST | RESET SIGNAL | RSTB=0,DISPLAY OFF,DISPLAY FROM LINE 0. |
| 18 | VEE | NEGATIVE VOLTAGE FOR LCD DRIVING | -10V |
| 19 | LED+ | SUPPLY VOLTAGE FOR LED+ | +5V |
| 20 | LED- | SUPPLY VOLTAGE FOR LED- | 0V |